

DPA73/153

AUDAC

PROFESSIONAL AUDIO EQUIPMENT

DPA73/153

Triple Channel Class-D Amplifier

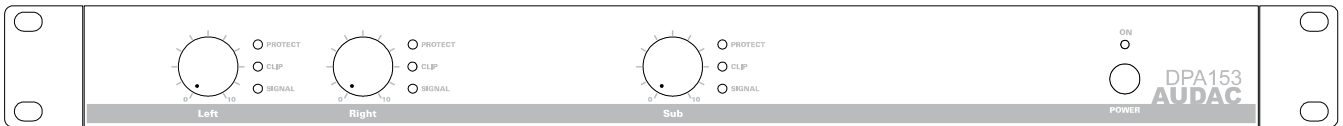

User Manual & Installation Guide

AUDAC PROFESSIONAL AUDIO EQUIPMENT

User Manual & Installation Guide

© AUDAC
<http://www.audac.eu>
info@audac.eu

Index

INTRODUCTION	3
ENVIRONMENT	4
SAFETY REQUIREMENTS	5
CAUTION – SERVICING	5
OVERVIEW FRONT AND REAR PANEL	6
FRONT PANEL OVERVIEW	6
FRONT PANEL DESCRIPTION	6
REAR PANEL OVERVIEW	7
REAR PANEL DESCRIPTION	7
CONNECTING THE AMPLIFIER	9
INPUT CONNECTIONS	9
OUTPUT CONNECTIONS	11
CONNECTIONS STANDARDS	12
BLOCK DIAGRAM	13
ADDITIONAL INFORMATION	14
TECHNICAL SPECIFICATIONS	14
PERSONAL NOTES	15

Introduction

This section briefly describes the possibilities of the DPA73/153 Class-D Power Amplifiers.

The DPA series amplifiers are digital power amplifiers designed to meet the specialized needs of sound contractors. They are designed in six different models of Class D power amplifiers, divided in three different architectures to meet the requirements for all kinds of applications.

They combine the best of all features in one single series of amplifiers, providing an outstanding sound quality with all the known advantages of Class D Amplifiers. Such as the excellent efficiency and very low heat dissipation. And due to the complete passively cooled entity only a minimal of maintenance is needed, while ensuring maximum reliability.

The small size of a single rack space make them very interesting for fixed rack mount as well as mobile applications.

The DPA73 and DPA153 are two channel (stereo) Class D amplifiers with an additional channel for powering a subwoofer cabinet. They are capable of delivering a power up to 2 x 150 Watt to the stereo channels and 300 Watt to the subwoofer channel

The signal input connections are accommodated with balanced XLR connectors and signal link through with other amplifiers is possible using the XLR output connectors. The operation mode can be selected between Stereo mode, Bridge mode and Parallel mode.

The output connections are accommodated with Euro-Terminal block connectors.

Environment

Do not place this unit in an enclosed environment such as a bookshelf or closet. Ensure that there is adequate ventilation to cool the unit.

Do not place the unit in environments which contain high levels of dust, heat, moisture or vibration.

Do not use the unit near water or other liquids. Make sure no water or other liquids can be spilled, dripped or splashed on the unit.

This unit was developed for indoor use only. Do not use it outdoors.

Do not place objects on top of the unit.

Place the unit on a stable base or mount it in a stable 19" rack.

Safety Requirements

Always handle the unit with care.

Only use a grounded socket outlet and a power cord with grounding plug to plug in the unit.

This unit is not a toy. It should not be operated by children.

Do not stick objects through the openings.

Do not open the unit (risk for electrical shock).



CAUTION – SERVICING

This unit contains no user serviceable parts. Refer all servicing to qualified service personnel. Do not perform any servicing unless you are qualified to do so.

Note

This product conforms to the following European Standards: EN 50081-1: 1992, EN 50082-1: 1992, EN 60065: 19

Overview front and rear panel

Front panel overview

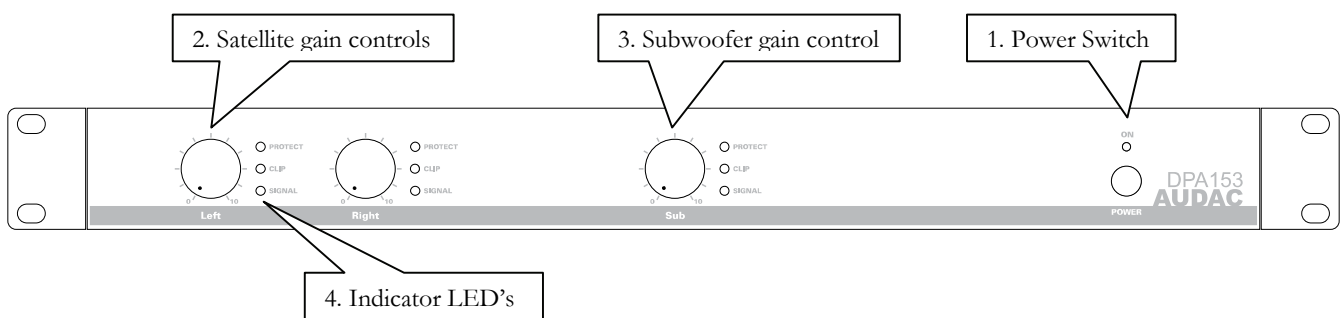

Description

1. Power switch:

By means of the power switch, the amplifier can be turned ON and OFF. When the amplifier is switched on, the blue LED located above the power button will illuminate.

2. Satellite gain control knobs:

By means of these rotary gain control knobs, the level for each individual satellite channel (Left & Right) can be controlled.

3. Subwoofer gain control knobs:

By means of this rotary gain control knob, the level for the subwoofer channel can be controlled.

4. Indicator LED's:

These LED's indicate the operation of the amplifier. There are three LED's provided. A signal indicator, a Clip indicator, and a Protect indicator. The green signal indicator LED's will light up when the input channel exceeds -20 dBu. The yellow clip LED's will illuminate when the channel's output is being overdriven, and the red protect indicators illuminate when the thermal compression begins, or any fault is detected.

Rear panel overview

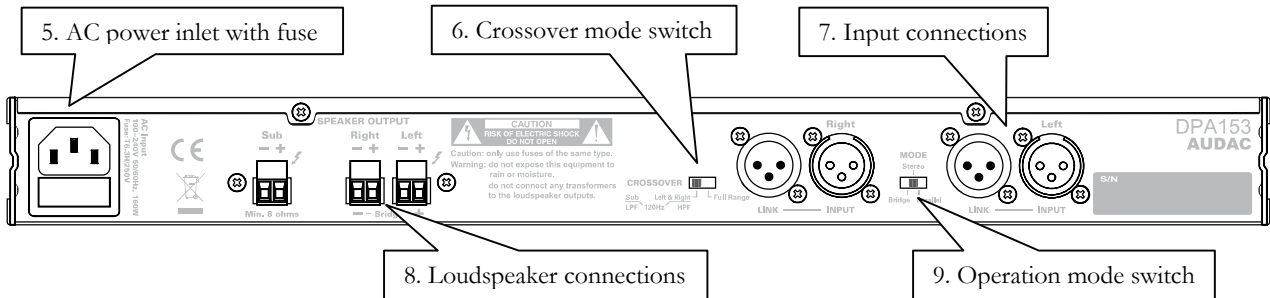

Description

5. Power inlet:

The mains power supply (100~240V AC / 50~60 Hz) has to be applied to this AC power inlet. The connection is made by an IEC power connector and is fitted with a fuse. When replacing the fuse, make sure that the value of the replacement fuse matches the value of the original fuse. (T4AL/250V for DPA73 & T6.3AH/250V for DPA153)

6. Crossover mode switch:

By means of this switch, the crossover mode can be selected between two different operation modes. Bass tones below 120 Hz are always filtered through a Low Pass filter (LPF), and are audible through the “Subwoofer channel”, while the signal present on the Left & Right output channels can be selected between “Full Range” and “Two-Way” operation.

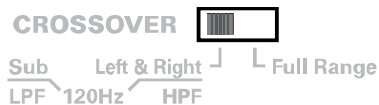

When the switch is in left position, the signal for the Satellite outputs is filtered through a High-Pass filter (HPF) and only the tones with a frequency above 120 Hz will be audible through the Satellite channels, while when the switch is in the right position, the Full Range audio signal (including tones below 120 Hz) will be audible through the audio channels.

The suitable operation mode depends of the type of application and the type of loudspeakers which are used.

7. Input connections:

The input connections of the amplifier are performed using balanced XLR connectors. Every channel has an XLR input connector and a XLR link output connector. The input signal from the signal source, pre-amplifier or mixer should be connected to the XLR input connections. And by means of the XLR link output connectors, the signal can be linked through to multiple amplifiers.

8. Loudspeaker connections:

The loudspeaker output connections are performed by means of Euro Terminal Blocks. A detailed description about the best method for connecting the loudspeakers for every application can be found in the next chapter, connecting the amplifier.

9. Operation mode switch:

By means of this switch, the operation mode of the amplifier can be selected between standard stereo mode, parallel mode and bridge mode. For standard stereo applications, this switch should be turned to center position for “Stereo” mode.

Connecting the Amplifier

Input connections

The input connections of the amplifier are performed using balanced XLR connectors. Every channel has an XLR input connector and a XLR link output connector.

The input signal from the signal source, pre-amplifier or mixer should be connected to the XLR input connections. And by means of the XLR link output connectors, the signal can be linked through to multiple amplifiers.

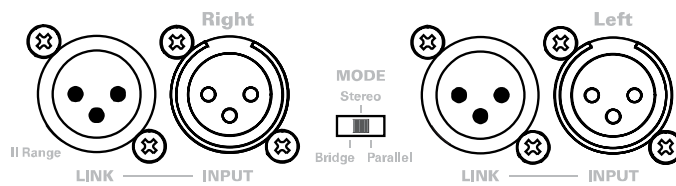

Between the input signal connections of the both channels is an operational mode switch provided. By means of this switch, the operational mode of the amplifier can be selected. There are three different operational modes available:

1) **Stereo Mode:**

This is the default mode how the amplifier is set in the factory, and will be the most common used setting for most applications (Center position of the switch).

Connect both outputs from the stereo signal source to the Left and Right XLR input connectors of the amplifier.

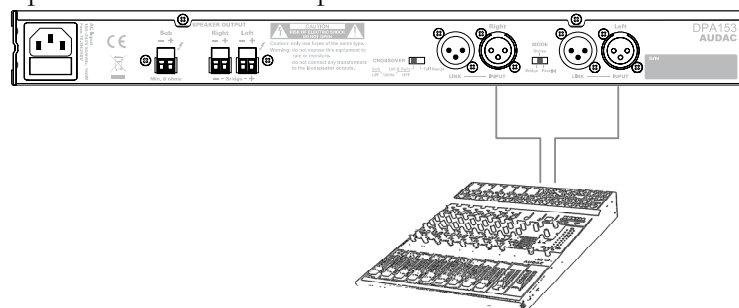

2) **Bridge mono Mode:**

In bridged mono mode, the power of both Satellite output channels (Left & Right) is merged to deliver double the power to one single 8 Ohm load. The mode selection switch should be positioned in the Bridge position (Left position of the switch).

The output of the signal source should only be connected with the Left channel XLR input connector of the amplifier.

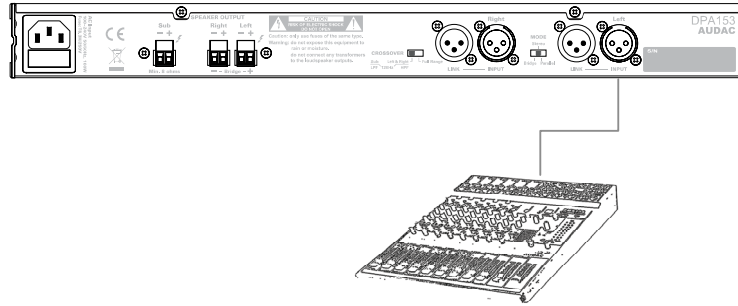

For more information about how the loudspeakers should be connected in bridge mode, refer to the “Output Connections” section of this user manual.

3) **Parallel Mode:**

In parallel mode (Right position of the switch), the amplifier is configured in a way that only the signal applied to the XLR input connector of the Left channel will be used, and will be amplified by both satellite and subwoofer output channels.

The output level of both channels can be individually controlled by means of the rotary controls on front of the amplifier.

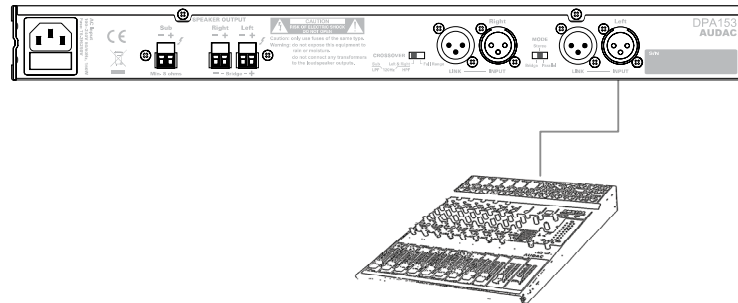

Output connections

The loudspeaker connections for every output channel are performed with a two pin Euro-Terminal block connector. On the Left side is the output connector of the Subwoofer channel provided, while on the right channel both output connectors for the Left & Right Satellite channels are provided.

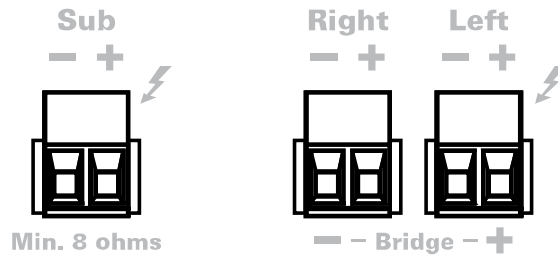

1) Stereo Mode:

Stereo mode will be the most commonly used operation method for this amplifier. The Satellite loudspeakers should be connected to the “Left & Right” Euro-Terminal block output connectors, while the subwoofer should be connected to the “Sub” Euro-Terminal block connector. Depending of the position of the “Crossover mode switch”, the signal which is available on the Left & Right outputs can be determined. For a more detailed description of the “Crossover mode switch” see “Rear panel overview” on page 7 of this user manual.

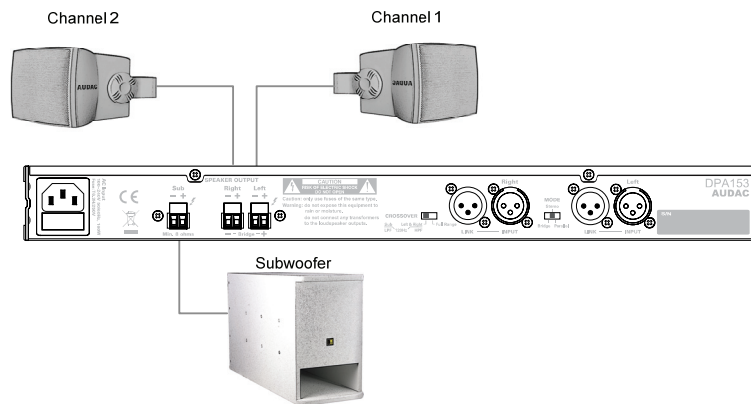

2) **Bridge mono Mode:**

When the amplifier is switched in bridge mode, there will be one single load connected to the amplifier outputs. This load should be connected between the + terminal of the Left channel and the – terminal of the Right channel.

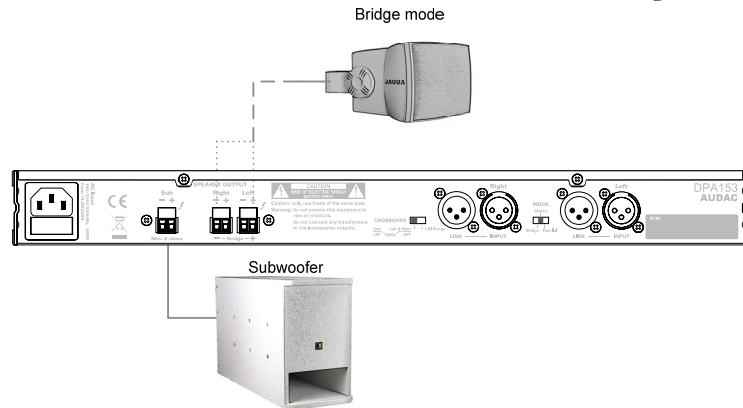

3) **Parallel Mode:**

When the amplifier is switched in parallel mode, the connections for the loudspeakers should be made in the same way as Stereo mode.

Note

Do not connect any 100V line transformers to the loudspeaker outputs of the amplifier. The minimum load for the subwoofer channel is 8 Ohm.

Connection standards

The in- and output connections of AUDAC audio equipment are performed corresponding to international wiring standards for professional audio equipment.

XLR:

1 = ground / shield

2 = +sig

3 = -sig

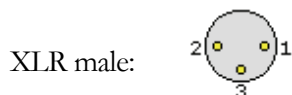
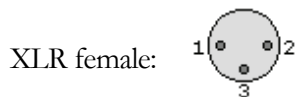

Block Diagram

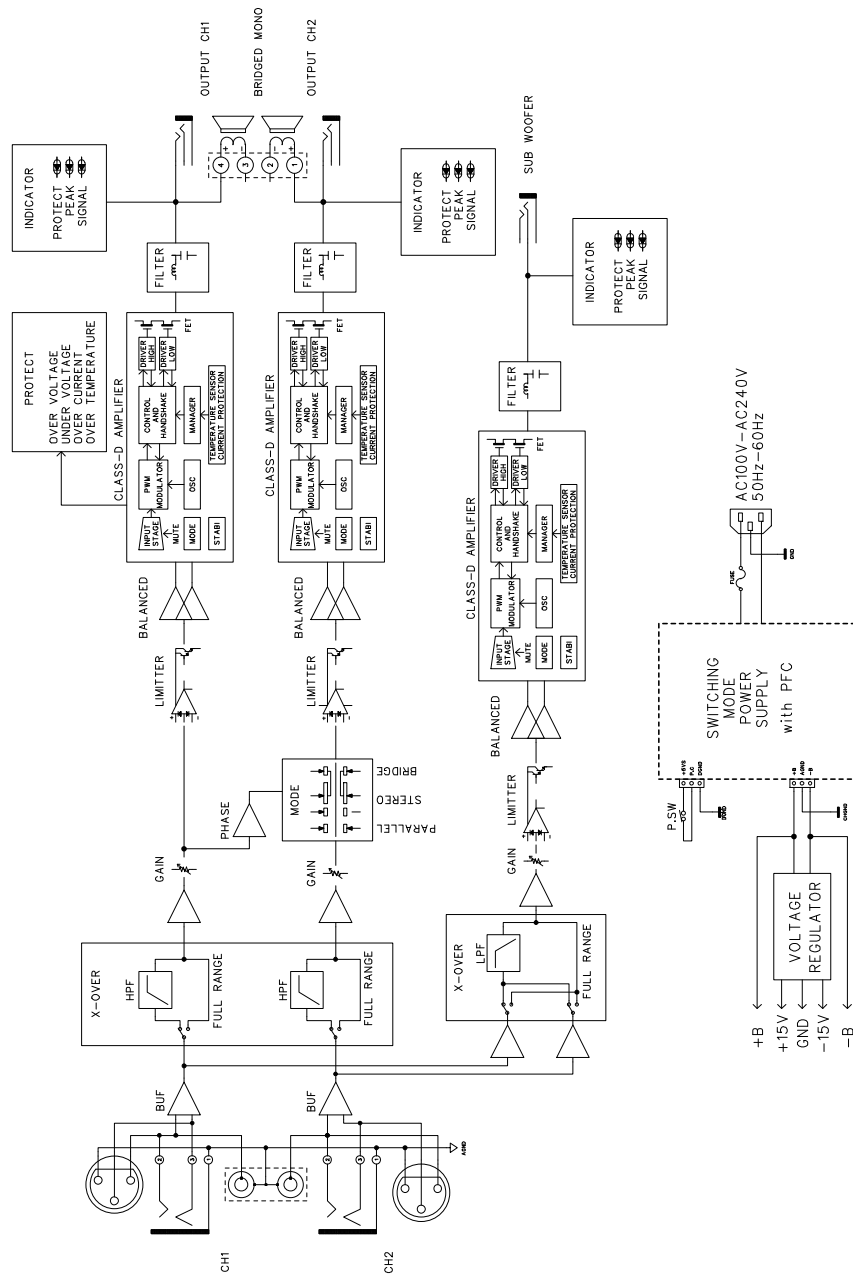

Additional Information

Technical specifications

		DPA73	DPA153
Performance			
Rated power (1 kHz, THD 1%)	Satellite Stereo @ 8 Ohm	2 x 50 Watt	2 x 80 Watt
	Satellite Stereo @ 4 Ohm	2 x 75 Watt	2 x 150 Watt
	Satellite Bridge @ 8 Ohm	150 Watt	300 Watt
	Subwoofer @ 8 Ohm	150 Watt	300 Watt
Input Sensitivity (Impedance 20 kOhm)		+ 4 dBm	
Frequency response (± 1 dB)		20 Hz – 20 kHz	
Signal to Noise ratio		> 90 dB	
Channel separation		>70 dB	
THD at 1 kHz (1/2 rated power)		Less than 0.1%	
Operation Temperature / Humidity at non condensing		0° ~ 40°C at 95% Humidity	
Indicators		Protect (DC, Thermal, Overload)	
		Clip (0 dBr)	
		Signal (-24 dBr)	
Power supply		100~240V AC / 50~60 Hz	
Construction			
Construction		Steel	
Cooling		Convection cooled	
Mounting		19" Rack	
Unit Height		1 HE	
Dimensions (W x H x D)		482 x 44 x 330 mm	
Color		Black	
Net Weight		4.58 Kg	4.83 Kg

Personal notes